

--	--	--	--	--	--	--	--	--	--

## First/Second Semester B.E. Degree Examination, Jan./Feb. 2023 Elements of Civil Engineering and Mechanics

Time: 3 hrs.

Max. Marks: 100

*Note: Answer any FIVE full questions, choosing ONE full question from each module.*

### Module-1

- 1 a. Describe the role of Civil Engineer in the development of nation. (10 Marks)
- b. List the different fields of Civil Engineering. Explain any four of them. (10 Marks)

**OR**

- 2 a. Describe the building material Brick with neat sketch. (10 Marks)
- b. Describe the different types of concrete. (10 Marks)

### Module-2

- 3 a. State and prove parallelogram law of forces. (08 Marks)
- b. Find the magnitude, direction and position of the resultant with respect to point 'A' for the force system shown in Fig.Q3(b).

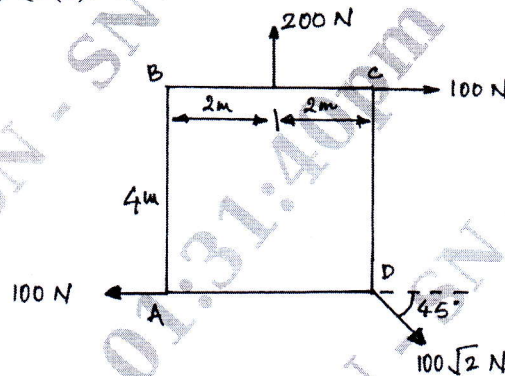

Fig.Q3(b)

(12 Marks)

**OR**

- 4 a. State and prove Varignon's theorem. (08 Marks)
- b. The coefficient of friction are  $\mu_s = 0.3$  and  $\mu_k = 0.25$  between all surfaces of contact. Determine the smallest force 'P' required to just start block 'D' moving if
  - i) Block 'C' restrained by cable AB
  - ii) Cable AB is removed.
 Refer Fig.Q4(b).

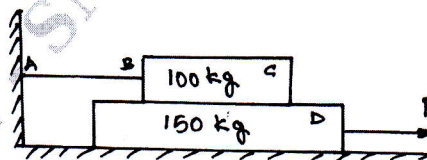

Fig.Q4(b)

(12 Marks)

### Module-3

- 5 a. Determine the centroid of triangle by method of integration. (08 Marks)
- b. Locate the centroid of plane lamina shown, in Fig.Q5(b). (12 Marks)

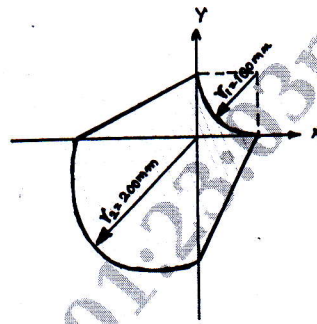

Fig.Q5(b)

OR

- 6 a. State and prove Parallel Axis theorem. (08 Marks)  
 b. Determine the Polar moment of inertia for the lamina shown in Fig.Q6(b).

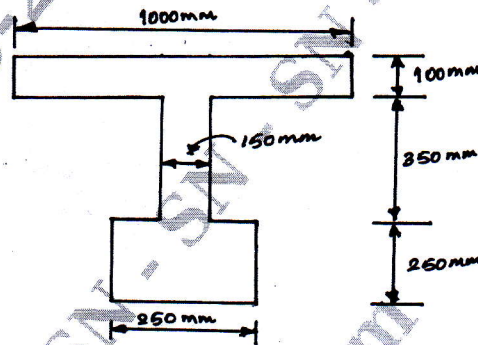

Fig.Q6(b)

(12 Marks)

Module-4

- 7 a. Explain the different types of beams with neat sketches. (08 Marks)  
 b. Determine the support reactions at A and B for the beam shown in Fig.Q7(b).

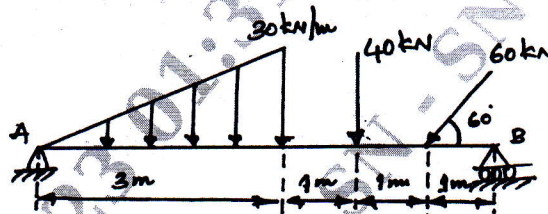

Fig.Q7(b)

(12 Marks)

OR

- 8 a. What are the assumptions made in the analysis of simple truss? (05 Marks)  
 b. Find the support reactions and member forces for the pin jointed plane truss shown in Fig.Q8(b).

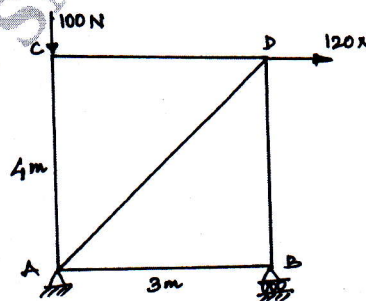

Fig.Q8(b)

(15 Marks)

**Module-5**

- 9 a. Derive all the three equations of motion in kinematics. (06 Marks)
- b. The motion of a particle is defined by the relation  $x = t^2 - (t - 3)^2$  m where x and t are in meters and seconds respectively. Determine (i) The time when velocity is maximum (06 Marks)  
(ii) the position and maximum velocity.
- c. A stone is thrown upward with a velocity of 40m/s. Determine the time of the stone when it is at a height of 10m and is moving downwards. (08 Marks)

**OR**

- 10 a. Explain the D'Alembert's principle. (06 Marks)
- b. A projectile is launched from a gun, after 3.783 seconds, the velocity of the projectile is observed to make an angle of  $30^\circ$  with the horizontal and at 4.79 seconds it reaches its maximum height, Calculate the initial velocity and angle of projection. (06 Marks)
- c. A hockey player hits a pack so that it comes to rest in 9 seconds after sliding 30m, horizontally on the ice. Determine
- i) The initial velocity of the Puck.
- ii) The coefficient of friction between puck and ice. (08 Marks)

\*\*\*\*\*